

REZULTATI ISPITIVANJA propustljivosti zraka jednokrlnog prozora sa IZO staklom 20 mm izrađenog od profila serije 45 MILL.

Propustljivost zraka:

ΔP Pa	Suzbijanje k. koef. m ³ /h·m m ³ /h·m		Ispustiti mjeraje m ³ /h			Kvaliteti mjeraje m ³ /h			Koeficijent propustivosti m ³ /h·m ² ·Pa ^{0.5}			Kritik. na stand. uvjete	
	A-II	C-III	I	II	III	IV	V	VI	1	II	III		
10	2,0	1,0	2,2	0,15	0,17	0,7	2,7	0,8	0,05	0,05	0,05	0,04	V ₁ - 2,0 - P - V/T
50	3,8	3,0	2,53	0,30	0,32	2,5	2,4	2,5	0,04	0,04	0,04	0,04	P - Ispr. Juk u 2 Pa
150	4,2	2,4	2,24	1,04	1,15	2	5	2,2	0,04	0,04	0,04	0,04	V - izd. u 2 Pa
300	4,0	2,0	2,56	1,46	1,67	7,1	7	8	0,04	0,04	0,04	0,04	T - izd. u 2 Pa
500	3,5	1,8	2,17	1,79	1,1	7	2,8	1,67	0,04	0,04	0,04	0,04	T - izd. u 2 Pa

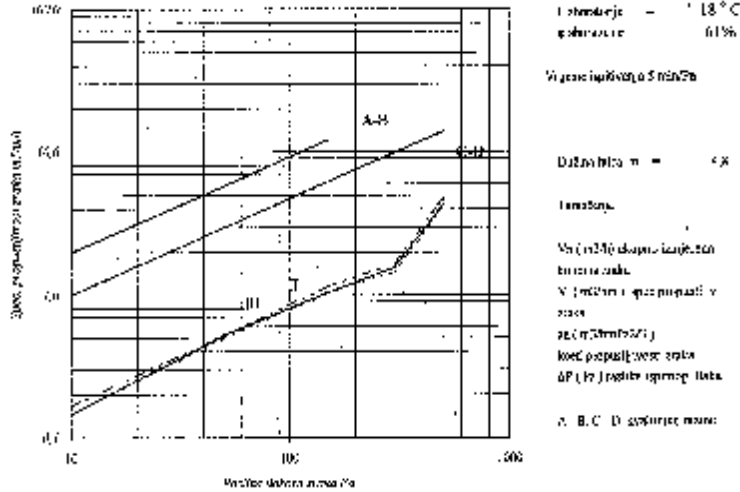

PROPUSTLJIVOST ZRAKA

- koeficijent propustljivosti $a_1 = 0.04 \text{ m}^3/\text{h} \cdot \text{m} \cdot \text{Pa}^0$
- proizvodi pripadaju kategoriji D (JUS D.E.8.193)

REZULTATI ISPITIVANJA propustljivosti vode jednokrlnog prozora sa IZO staklom 20 mm izrađenog od profila serije 45 MILL.

ispitivanje 10 min po

ΔP Pa	Q litre/h	Proba: vode			Kategor.
		I	II	III	
10	2	ne	ne	ne	A
50	2	ne	ne	ne	A
150	2	ne	ne	ne	B
300	2	ne	ne	ne	C
500	2	ne	ne	ne	D
1000	2	-	-	-	D

Površina obilježavanja A = 1,5 m²

PROPUSTLJIVOST VODE

- proizvodi pripadaju kategoriji D (JUS D.E.8.193)

PONAŠANJE KRILA U UPOTREBI: zadovoljava

KVALITET IZRADE: zadovoljava

OPĆA OCJENA KVALITETE "D"





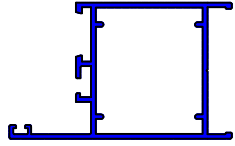
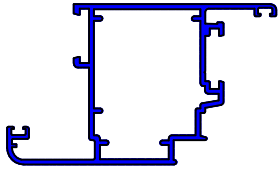
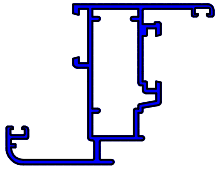
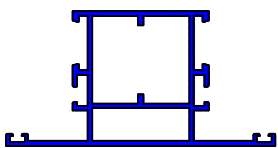
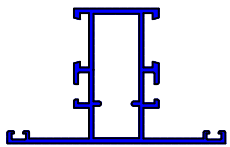
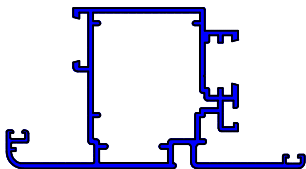
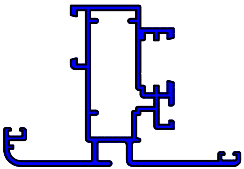
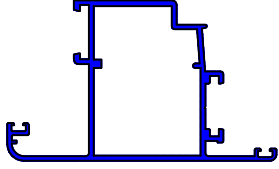
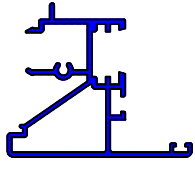

Odgovorna osoba
Mr. Šojin Stefo dipl. ing.



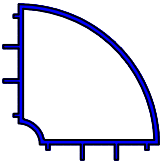

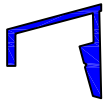
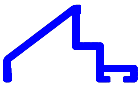



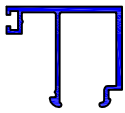
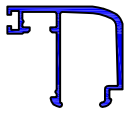
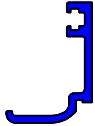
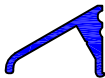
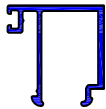
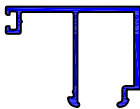

Šef katedre
Prof. dr. Raiman Vitko

Oznaka	Izgled-presjek	Težina /kg/m/	Opseg /mm/	Ix /cm ⁴ /	Wx /cm ³ /
M45-700		1.036	316		
M45-701		1.305	403		
M45-702		0.997	369		
M45-703		1.223	387		
M45-704		0.995	353		
M45-705		1.522	503		
M45-706		1.261	469		
M45-707		1.261	396		
M45-708		0.977	395		

Oznaka	Izgled-presjek	Težina /kg/m/	Opseg /mm/	I_x /cm ⁴ /	W_x /cm ³ /
M45-709		0.258	153		
M45-710		0.933	330		
M45-711		0.817	275		
M45-721		2.150	515		
M45-722		1.950	512		
M45-740		0.258	148		
M45-751		0.234	122		
M45-752		0.510	242		
M45-753		0.274	153		

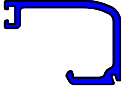
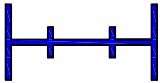
Oznaka	Izgled-presjek	Težina /kg/ml/	Opseg /mm/	I_x /cm ⁴ /	W_x /cm ³ /
M45-754		0.932	248		
M45-755		0.274	148		
060 350		0.285	107		
F-0228		0.153	68		
P45-648		0.257	140		
Z40-636		0.261	141		
Z40-644		0.275	166		
Z40-646		0.286	157		
Z40-647		0.226	137		

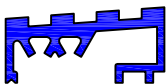
Oznaka	Izgled-presjek	Težina /kg/m/	Opseg /mm/	Ix /cm ⁴ /	Wx /cm ³ /
Z40-648		0.268	125		
Z40-649		0.221	105		
Z40-653		0.348	201		
Z40-653/B		0.356	197		
Z40-656		0.215	107		
Z40-657		0.186	73		
Z40-658		0.318	184		
Z40-659		0.359	204		
Z40-660		0.179	89		

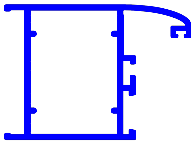
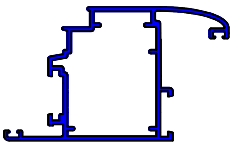
Oznaka	Izgled-presjek	Težina /kg/m/	Opseg /mm/	I_x /cm ⁴ /	W_x /cm ³ /
Z40-661		0.314	146		
P45-643		0.342	184		
F-0681		0.920	304		
F-0714		0.895	294		
060 353		0.825	225		
NC 1459		0.156	51		
P45-644		0.323	153		
M45-712		1.139	348		
M45-730		1.290	394		

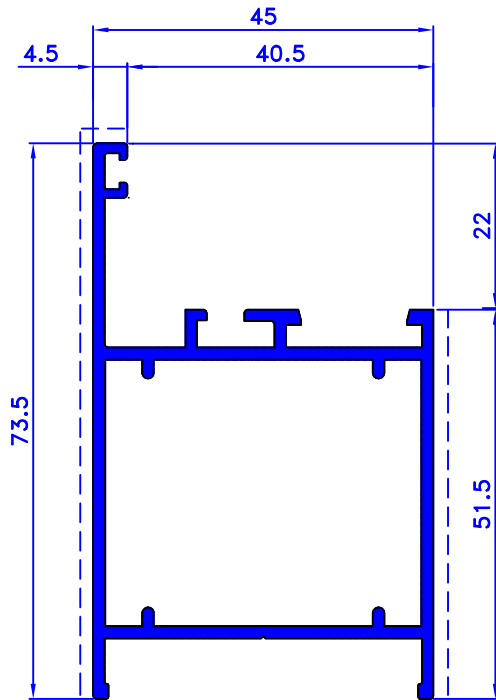

M45-700

težina: kg/ml 1.037
svj.povr. mm 130

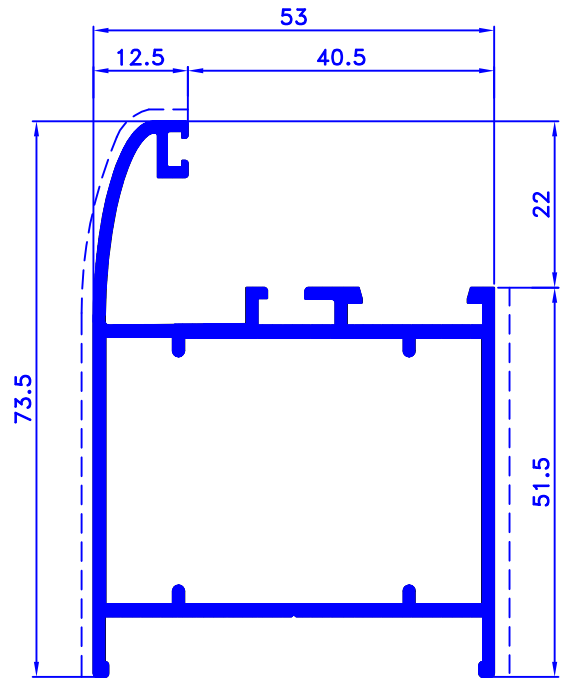

M45-712

težina: kg/ml 1.139
svj.povr. mm 134

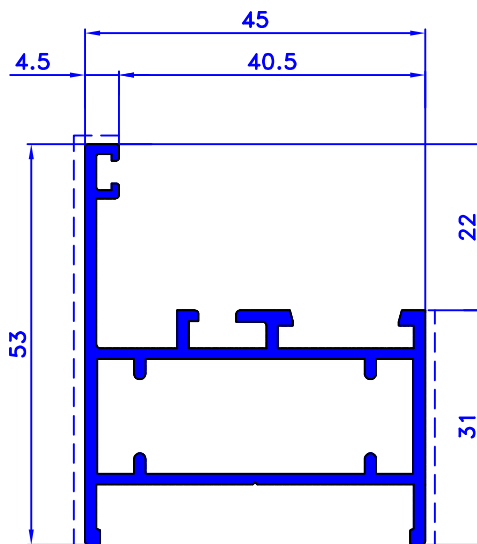

M45-711

težina: kg/ml 0.817
svj.povr. mm 89

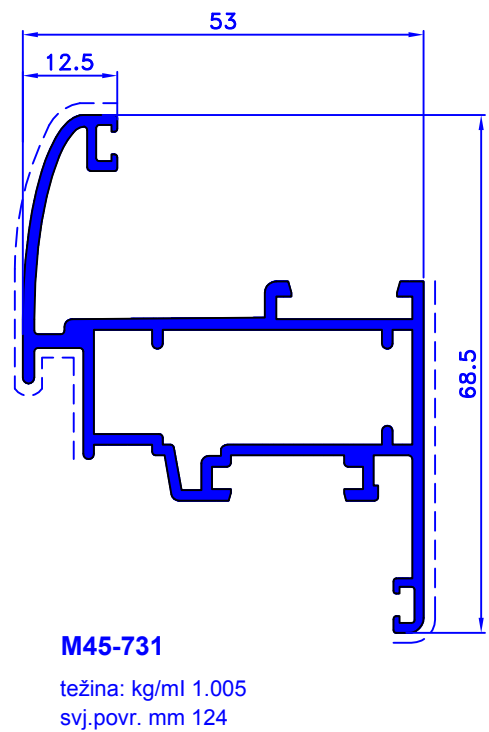
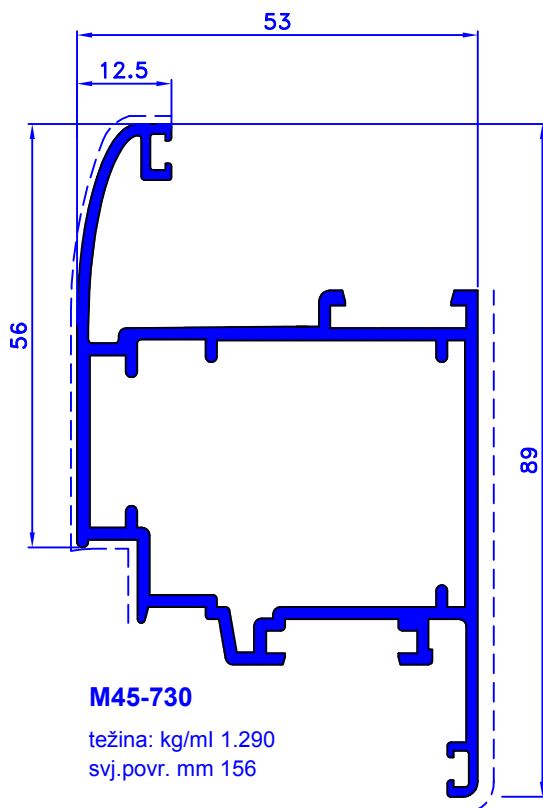
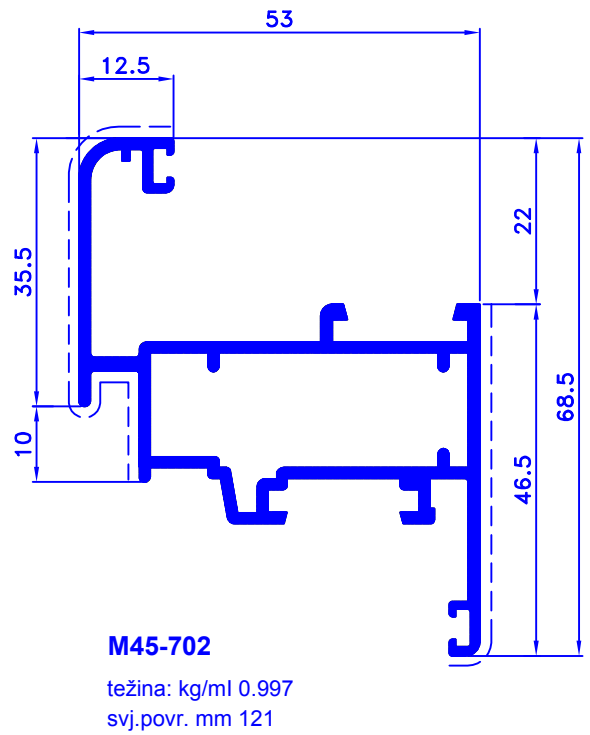
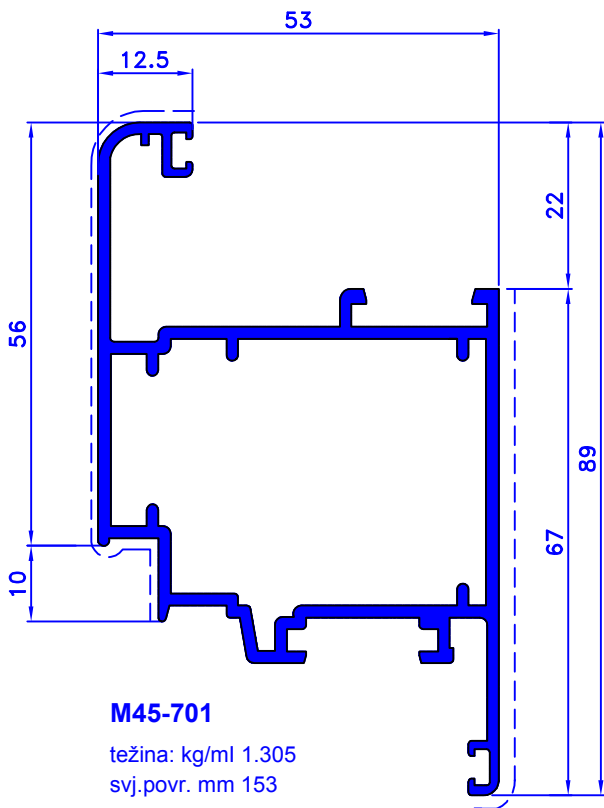

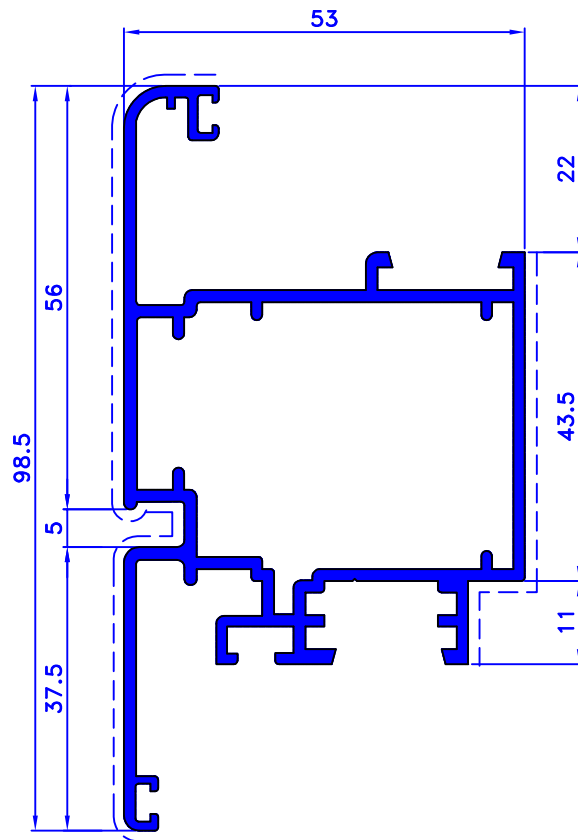

M45-705

težina: kg/ml 1.522
svj.povr. mm 195

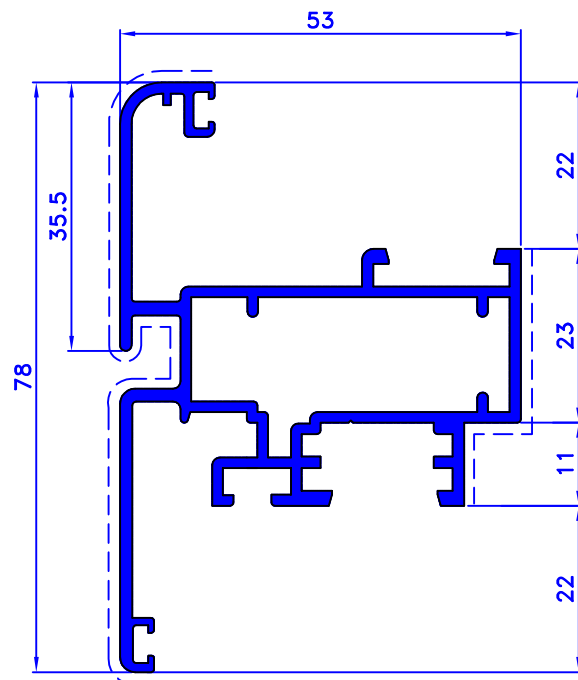

M45-706

težina: kg/ml 1.261
svj.povr. mm 157

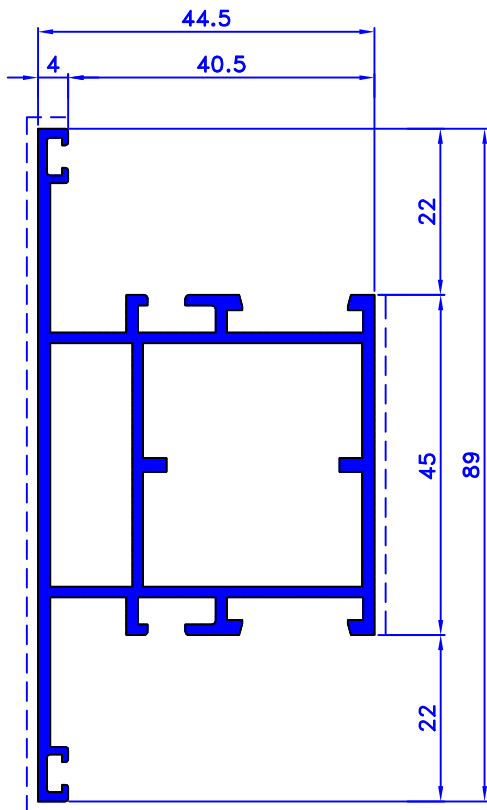

M45-703

težina: kg/ml 1.223
svj.povr. mm 142

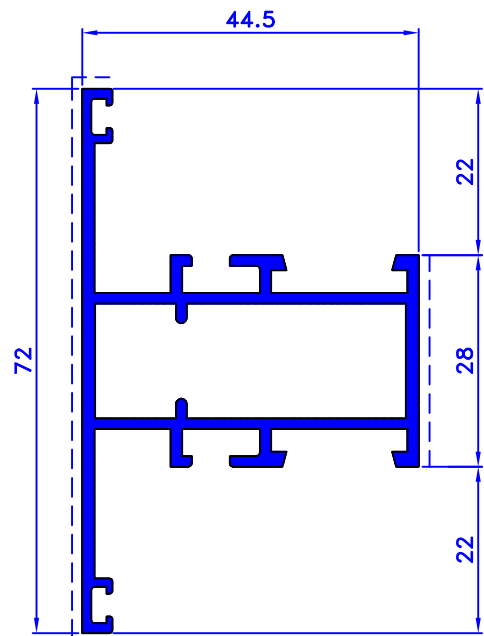

M45-704

težina: kg/ml 0.995
svj.povr. mm 108

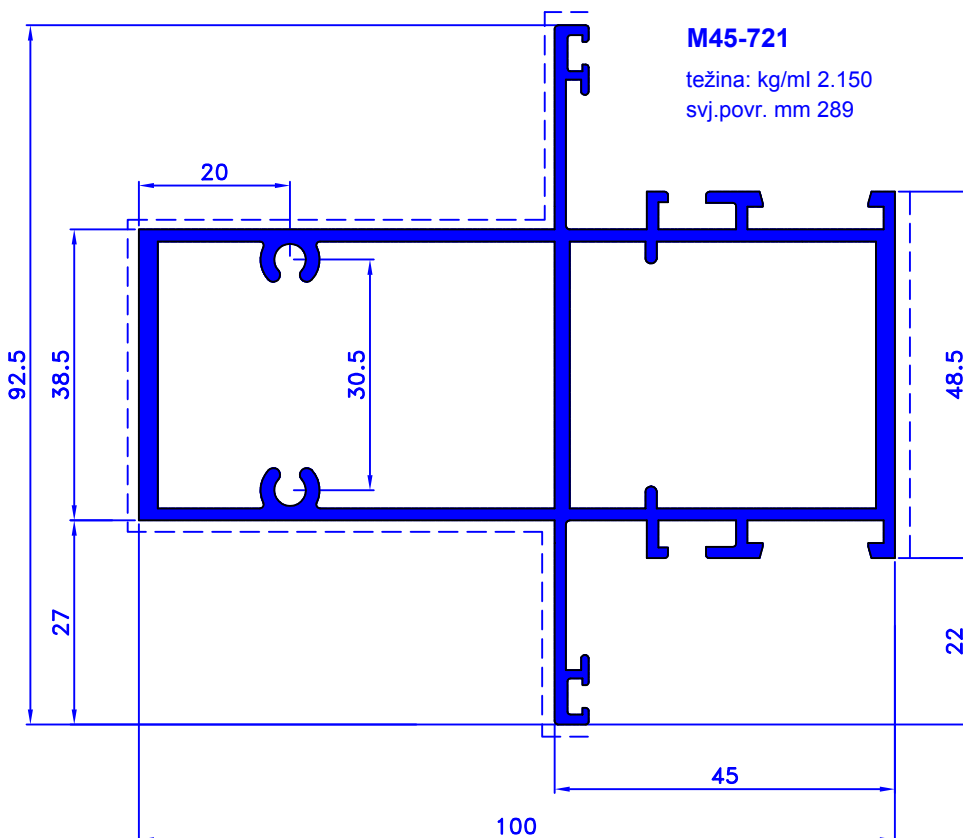

M45-721

težina: kg/ml 2.150
svj.povr. mm 289

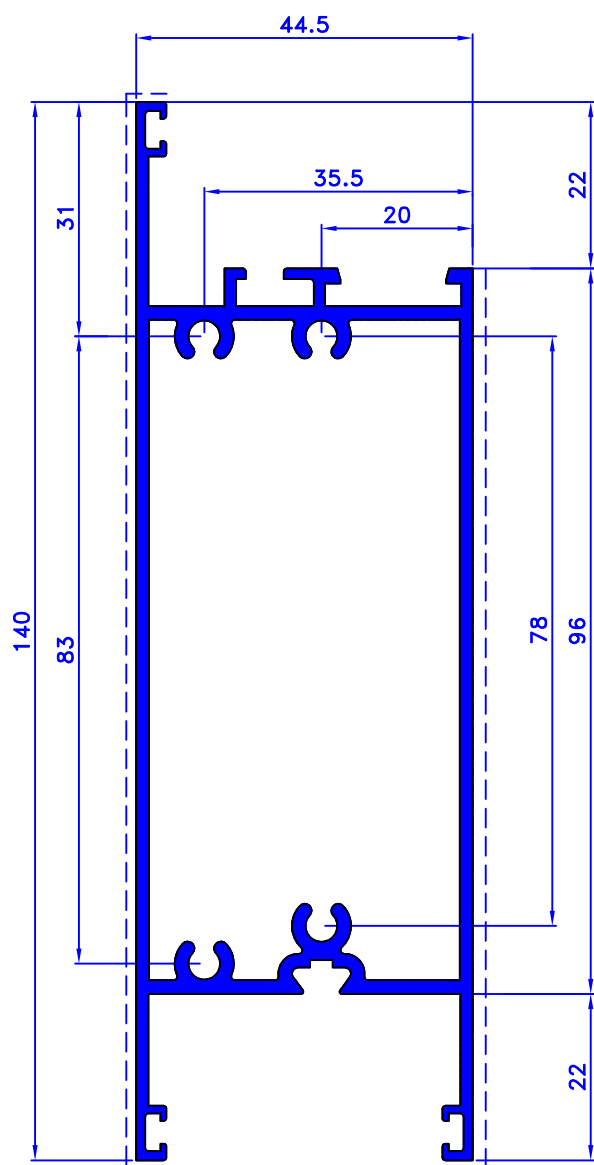

M45-722

težina: kg/ml 1.950
svj.povr. mm 270

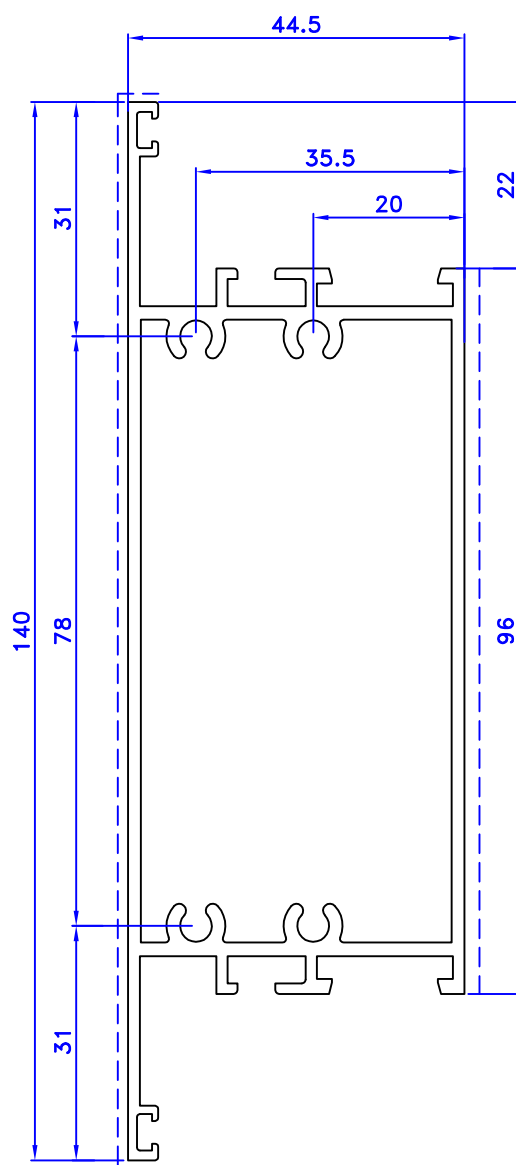

M45-723

težina: kg/ml 1.869
svj.povr. mm 244

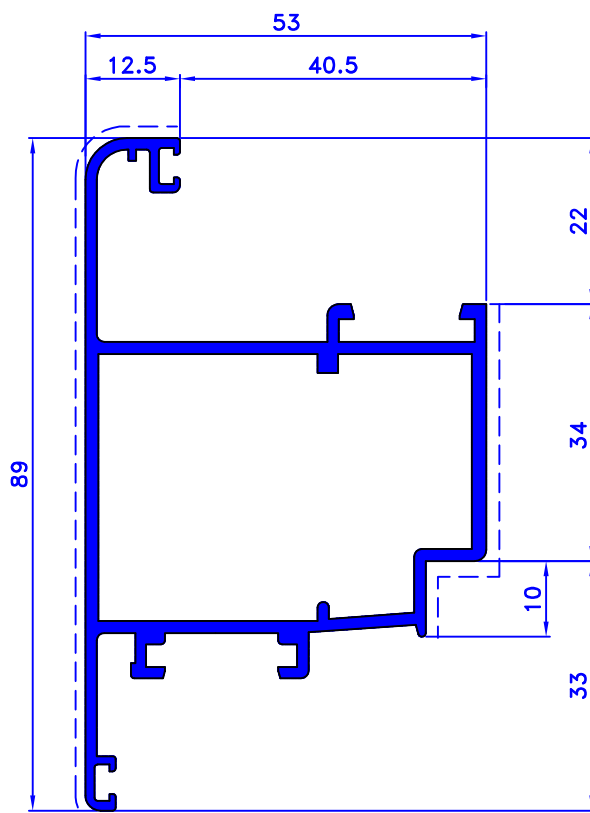

M45-707

težina: kg/ml 1.261
svj.povr. mm 158

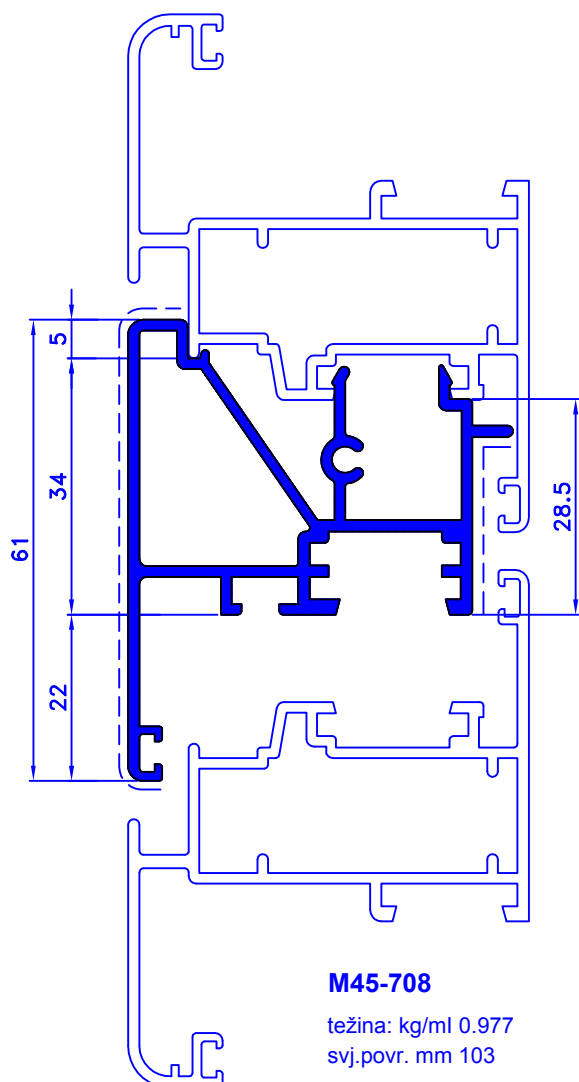

M45-708

težina: kg/ml 0.977
svj.povr. mm 103

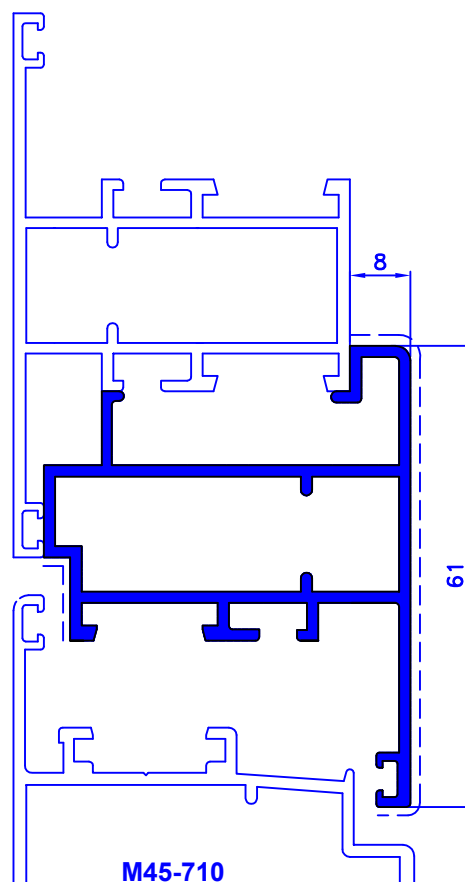

M45-710

težina: kg/ml 0.933
svj.povr. mm 88

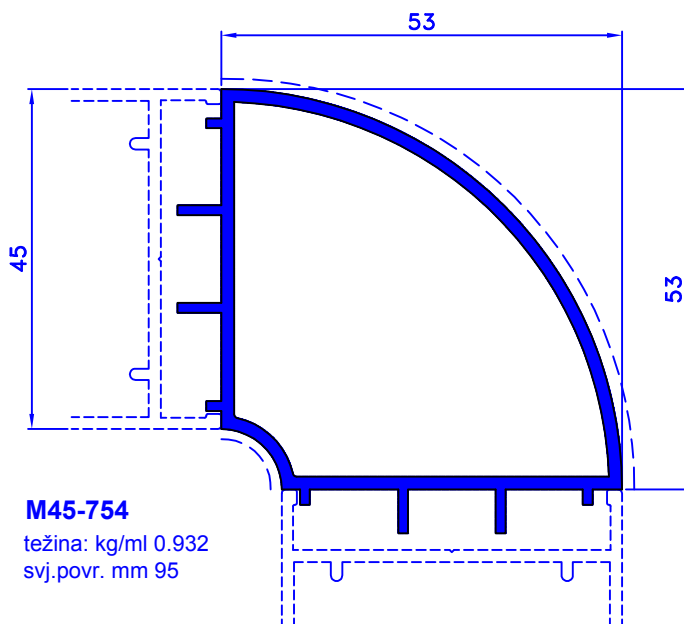
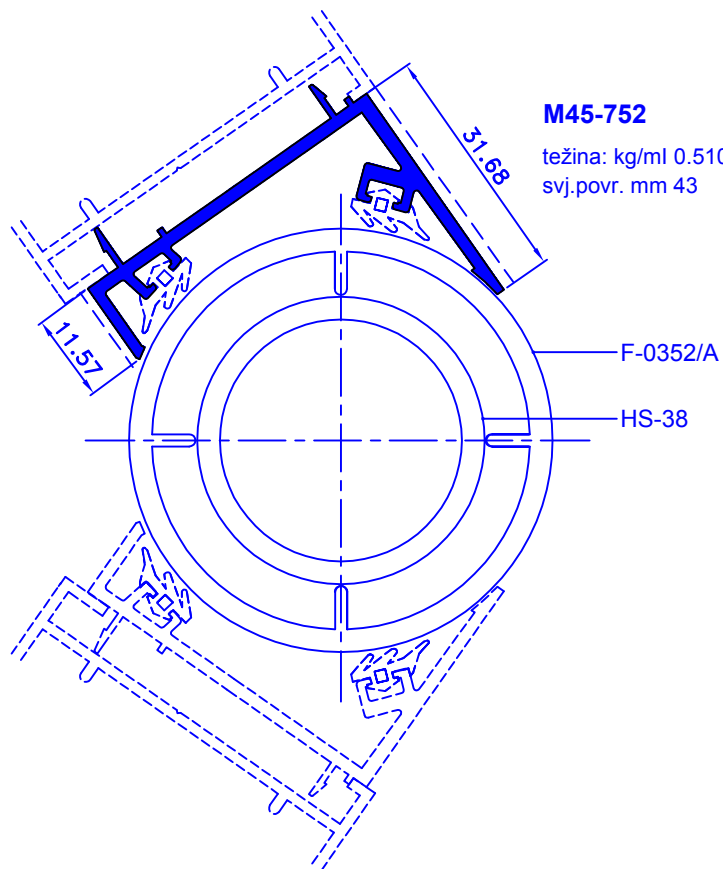

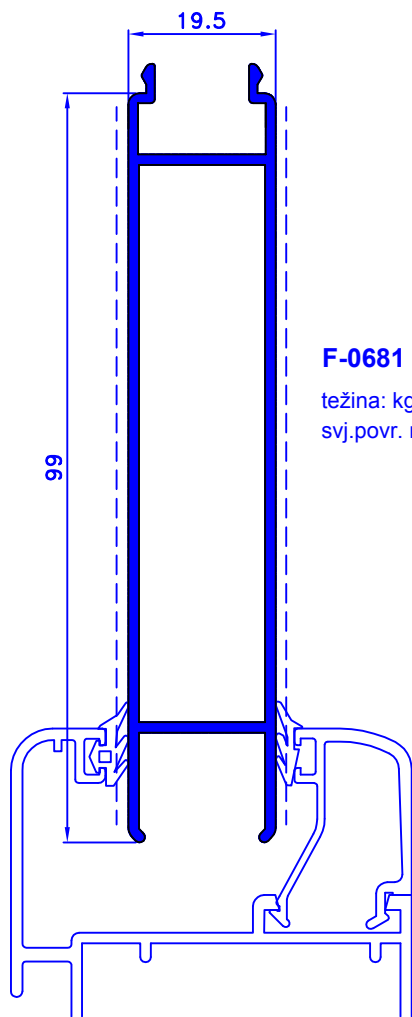

F-0681

težina: kg/ml 0.920
svj.povr. mm 195

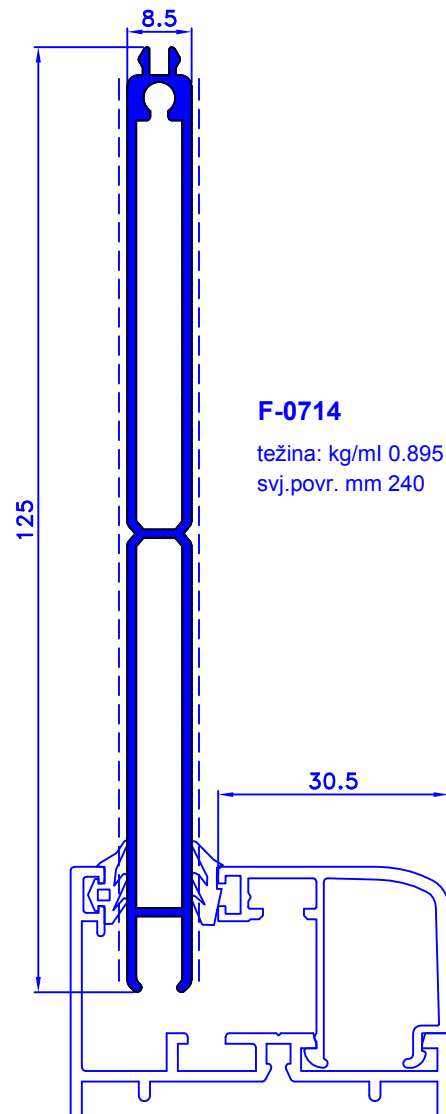

F-0714

težina: kg/ml 0.895
svj.povr. mm 240

30.5

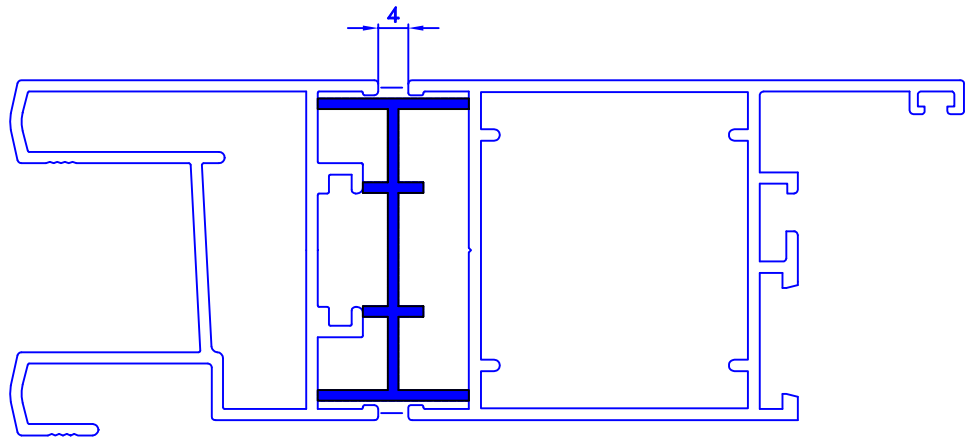

P45-643

težina: kg/ml 0.342
svj.povr. mm 8

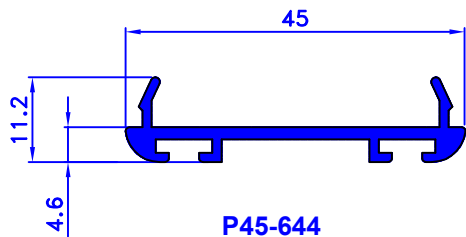

P45-644

težina: kg/ml 0.323
svj.povr. mm

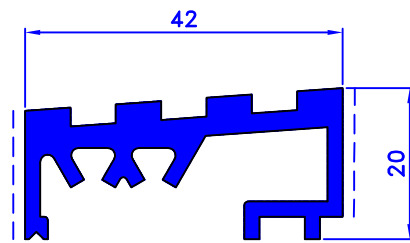

060 353

težina: kg/ml 0.825
svj.povr. mm 34

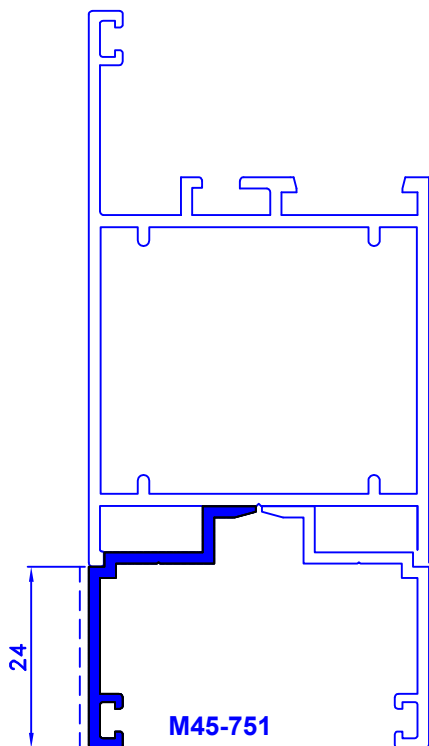

M45-751

težina: kg/ml 0.234
svj.povr. mm 24

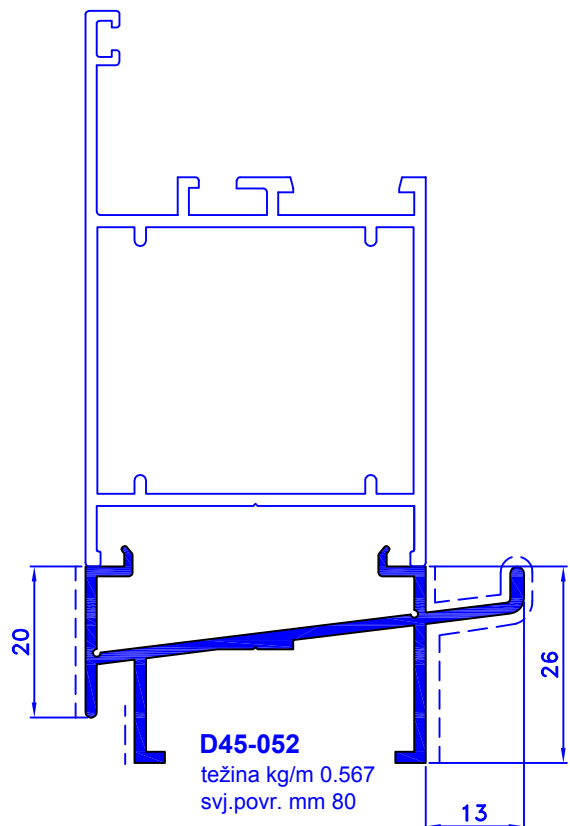

D45-052

težina kg/m 0.567
svj.povr. mm 80

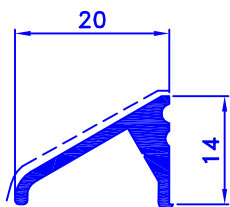

Z40-657

težina: kg/ml 0.186
svj.povr. mm 23

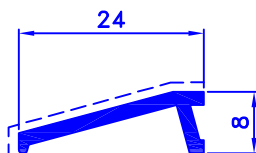

F-0228

težina: kg/ml 0.153
svj.povr. mm 27

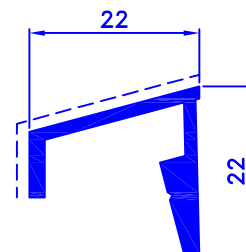

060 350

težina: kg/ml 0.285
svj.povr. mm 31

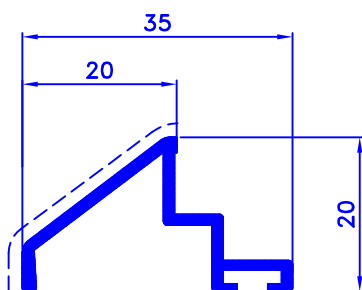

P45-648

težina: kg/ml 0.257
svj.povr. mm 33

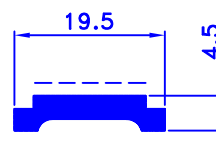

NC-1459

težina: kg/ml 0.156
svj.povr. mm 15

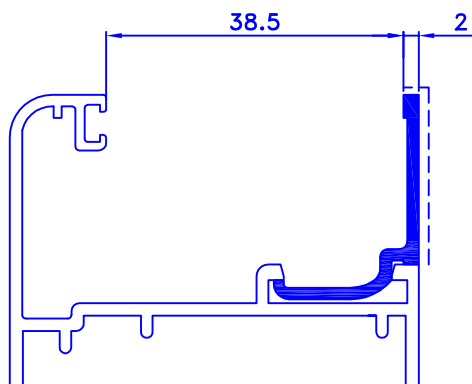

Z40-660

težina: kg/ml 0.179
svj.povr. mm 24

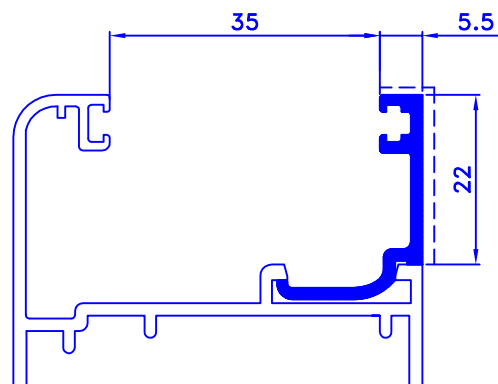

Z40-656

težina: kg/ml 0.215
svj.povr. mm 27

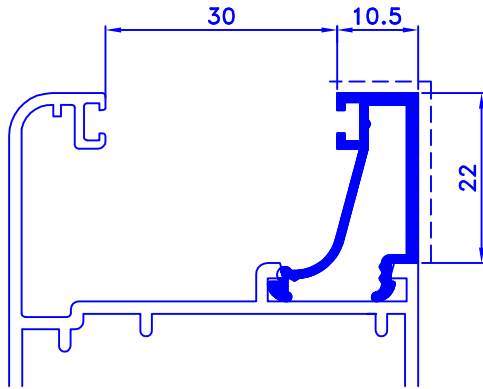

Z40-636

težina: kg/ml 0.261
svj.povr. mm 32

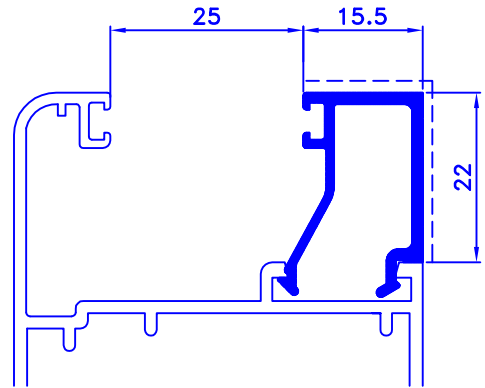

M45-709

težina: kg/ml 0.258
svj.povr. mm 37

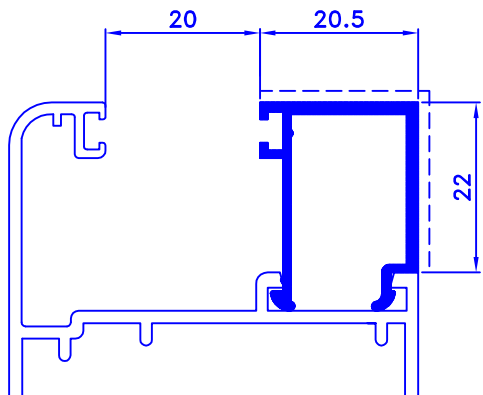

Z40-644

težina: kg/ml 0.275
svj.povr. mm 42

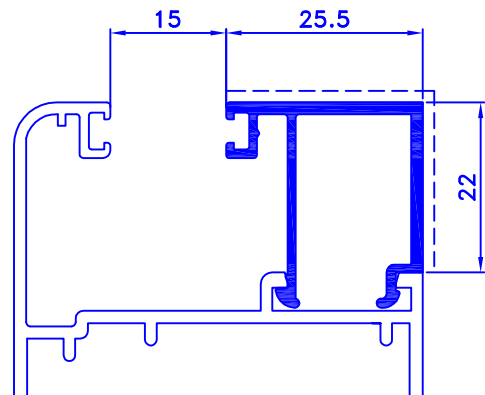

Z40-658

težina: kg/ml 0.318
svj.povr. mm 47

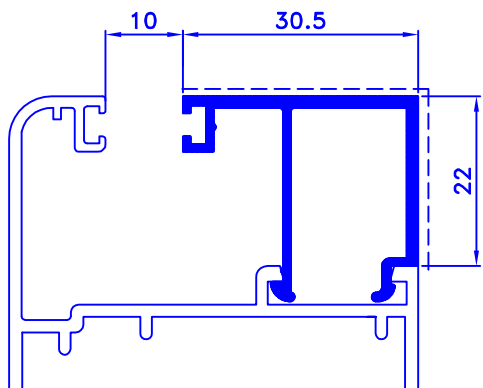

Z40-653

težina: kg/ml 0.347
svj.povr. mm 52

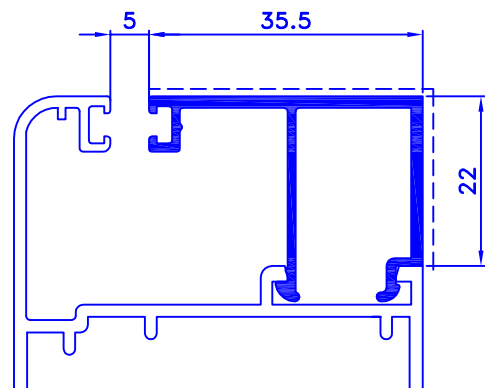

Z40-659

težina: kg/ml 0.359
svj.povr. mm 57

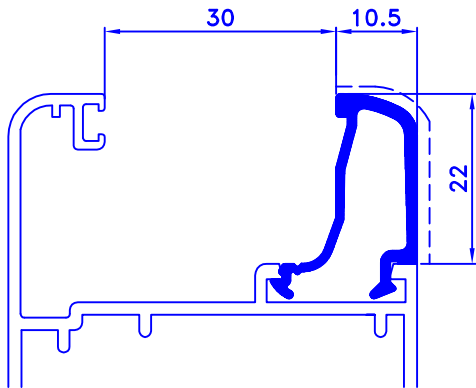

Z40-647

težina: kg/ml 0.226
svj.povr. mm 30

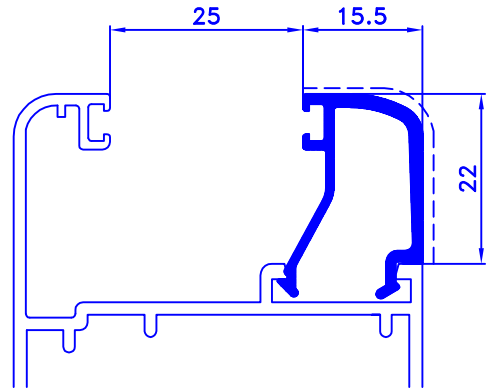

M45-740

težina: kg/ml 0.258
svj.povr. mm 35

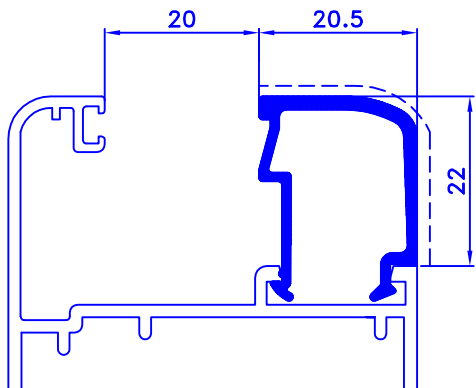

Z40-646

težina: kg/ml 0.286
svj.povr. mm 40

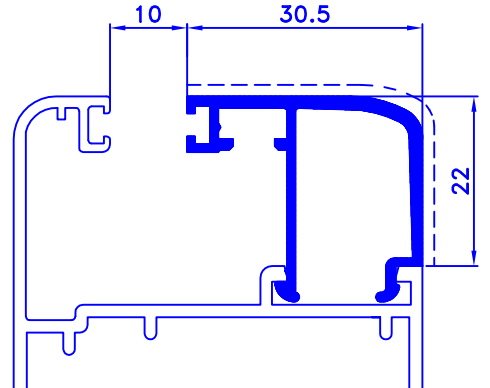

Z40-653/B

težina: kg/ml 0.356
svj.povr. mm 53

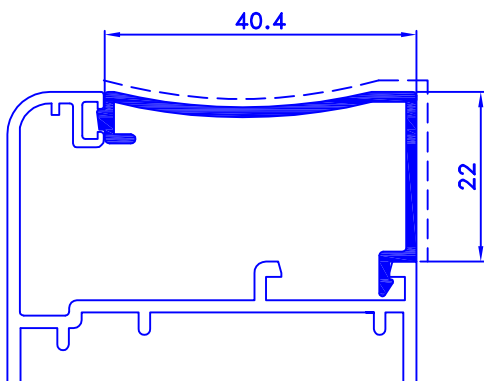

M45-755

težina: kg/ml 0.274
svj.povr. mm 64

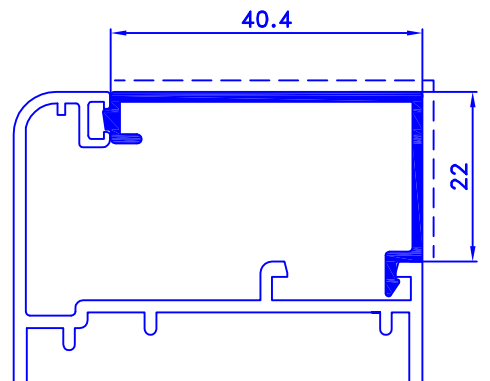

M45-753

težina: kg/ml 0.274
svj.povr. mm 63

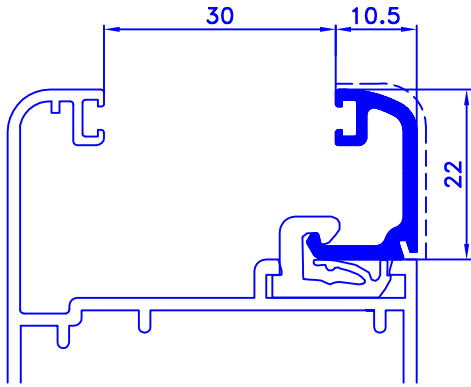

Z40-649

težina: kg/ml 0.221
svj.povr. mm 30

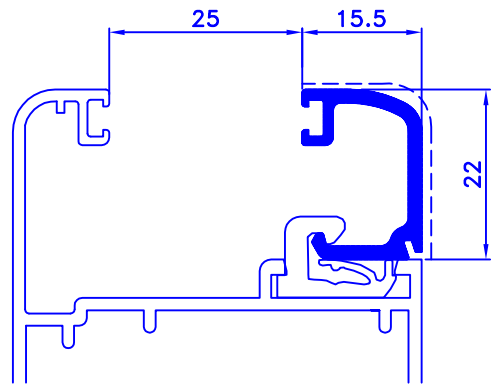

Z40-662

težina: kg/ml 0.245
svj.povr. mm 35

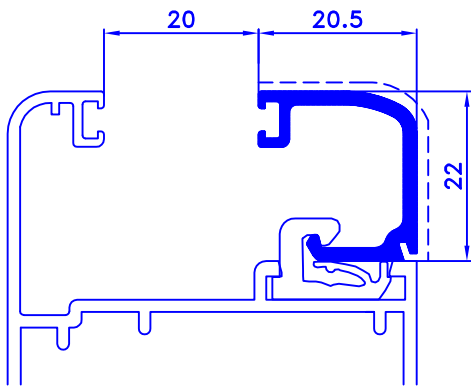

Z40-648

težina: kg/ml 0.268
svj.povr. mm 40

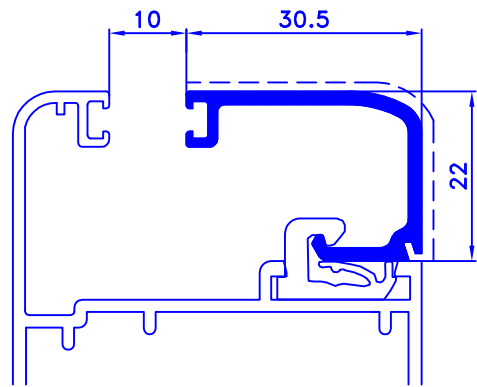

Z40-661

težina: kg/ml 0.268
svj.povr. mm 50